

STRETCHER DIMENSIONS

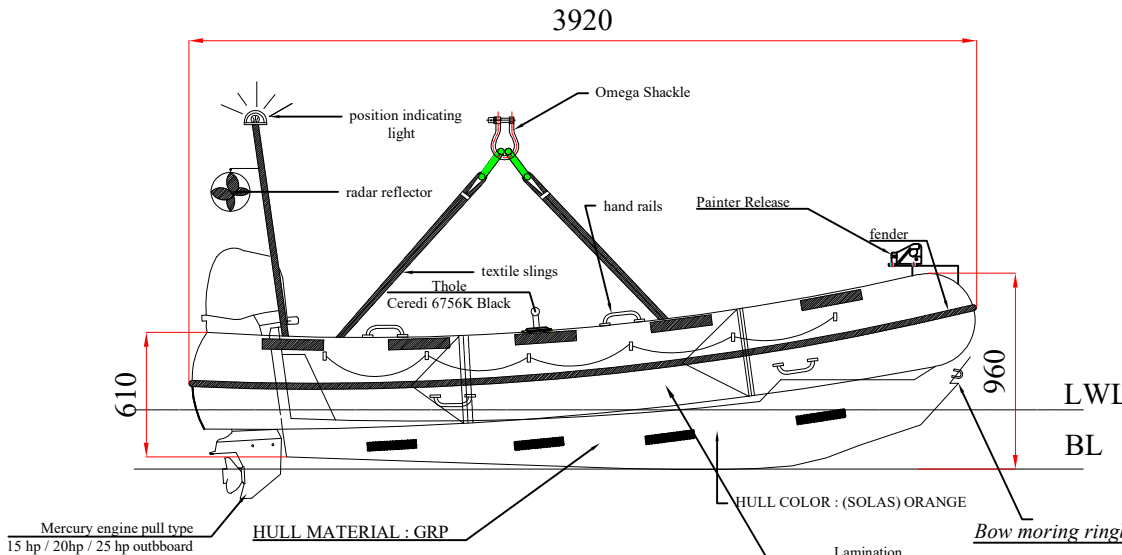
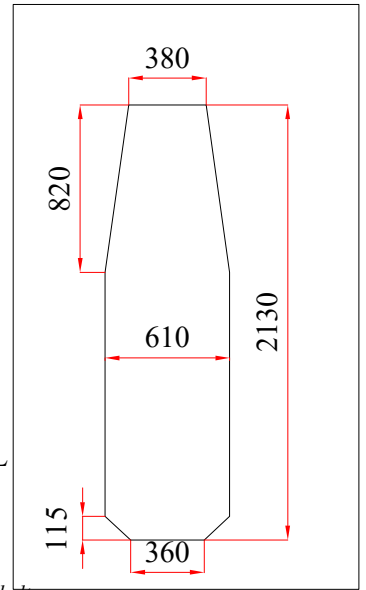

Mercury engine pull type
15 hp / 20hp / 25 hp outboard

HULL MATERIAL : GRP

HULL COLOR : (SOLAS) ORANGE

BOUYANCY TUBE FABRIC MATERIAL : Orca Silvano Orange 866723

TUBE COMPARTMENT : TOTAL 5 INDEPENDENT AIR COMPARTMENT

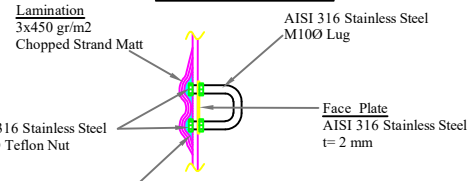

Righting Hold

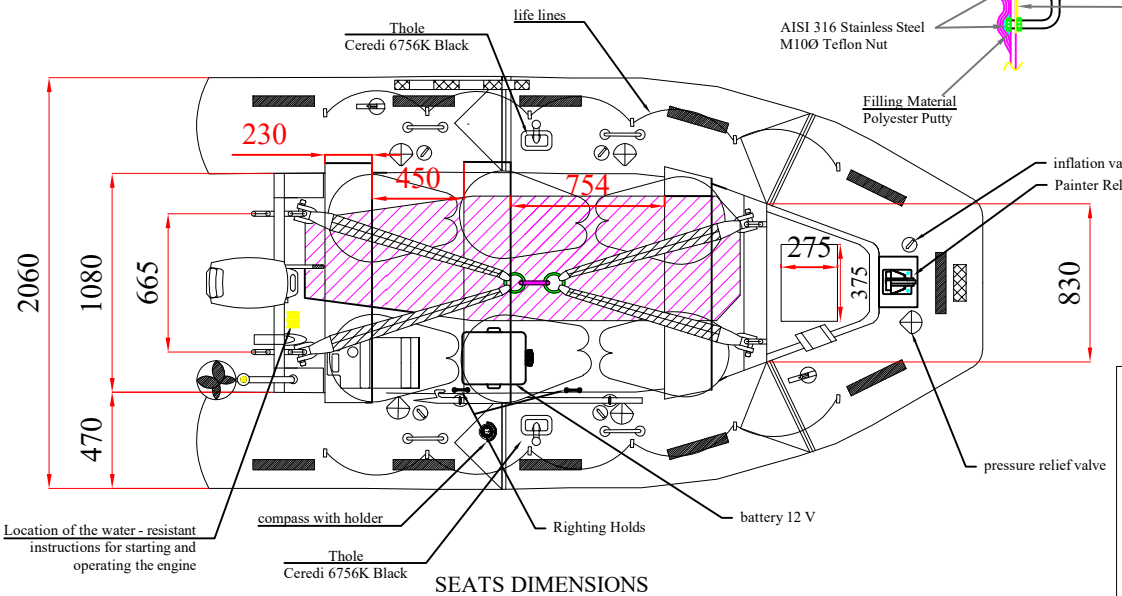
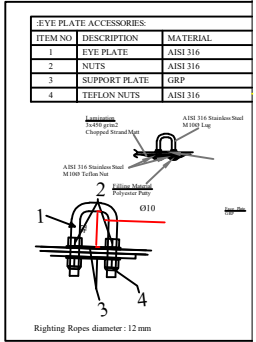

INDICATION LIGHT AND RADAR REFLECTOR

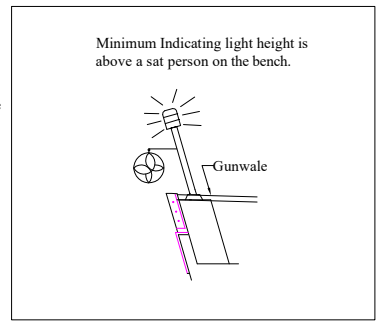

SEATS DIMENSIONS

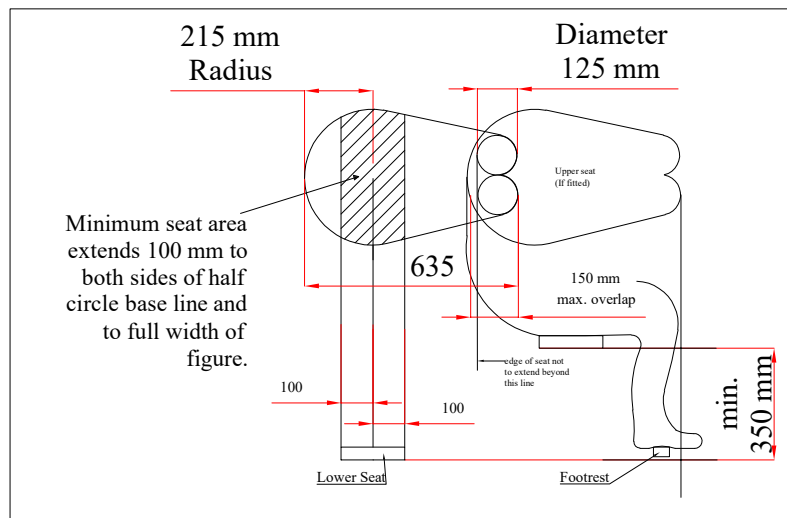

GENERAL DIMENSIONS

Lo.a.	3.92 m (inc. Fender)
L (hull)	3.00 m
Bo.a.	2.06 m (inc. Fenders)
Height	0.96 m
Draft	0.29 m
Capacity	6 Persons
Engine	Mercury 15 HP
Engine (Optional)	Mercury 20 HP
Engine (Optional)	Mercury 25 HP
Weight (Unloaded)	260 kg
Weight (Loaded)	755 kg

Rev. No.	REV.	Date
3		
2		
1		

GEPA FIBERGLASS INDUSTRY & TRADE CO. INC.
 Aydıntepe Mah. Harmandalı Sok. No:10, Aydıntepe
 34947 TUZLA / ISTANBUL / TURKEY

G-RIB1 TYPE INFLATED RESCUE BOAT

GENERAL ARRANGEMENT		DATE
		17.02.2022
CAD/CAE	Bahadır GÖKÇETERKİN	DRAWING NO.
DESIGN AND CONT.	Barbaros ONUR	G-RIB1-01
SCALE	CLASS	REV.
		00

Note : Righting ropes material is polypropylen fiber
 Righting ropes breaking load : 1.510 kgf
 Righting ropes diameter : 10 mm